

Jazz™ OPLC™ Micro-OPLC Installation Guide

JZ10-11-R10

6 Digital Inputs, 4 Relay Outputs

JZ10-11-R16/V

6 Digital, 2 Analog/Digital, 2 Analog Inputs, 6 Relay Outputs

- Before using this product, the user must read and understand this document.
- For additional information regarding this product, refer to the user guide and technical specifications.
- All examples and diagrams are intended to aid understanding, and do not guarantee operation. Unitronics accepts no responsibility for actual use of this product based on these examples.
- Please dispose of this product according to local and national standards and regulations.
- Only qualified service personnel should open this device or carry out repairs.



Failure to comply with appropriate safety guidelines can cause severe injury or property damage.



- Do not attempt to use this device with parameters that exceed permissible levels.
- To avoid damaging the system, do not connect/disconnect the device when power is on.

Environmental Considerations



- Do not install in areas with: excessive or conductive dust, corrosive or flammable gas, moisture or rain, excessive heat, regular impact shocks or excessive vibration.
 - Ventilation: 10mm space required between the OPLCs' top/bottom edges & enclosure walls.
- 
- Do not place in water or let water leak onto the unit.
 - Do not allow debris to fall inside the unit during installation.

Mounting

Dimensions

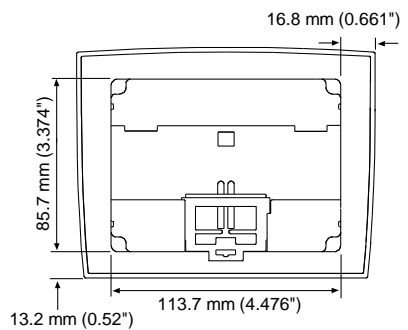
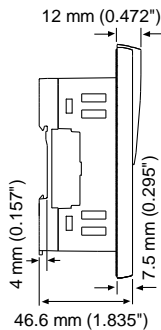
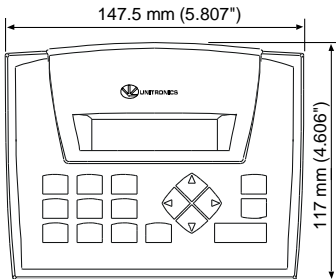

Add-on modules

Take into account that installing an add-on module requires sufficient clearance space.

During installation

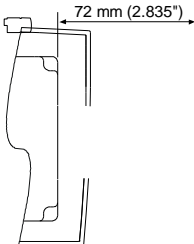

After installation

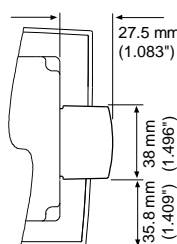

DIN-rail mounting

Snap PLC onto the DIN rail

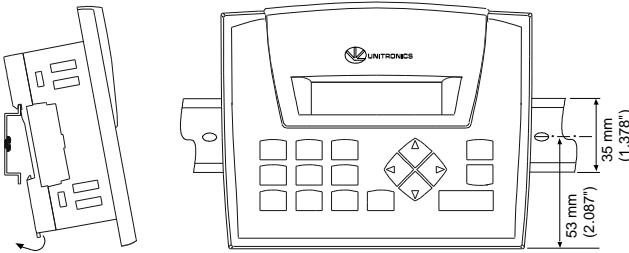

Panel mounting

Cut-out: 117 x 89mm (WxH)
4.606" x 3.504"

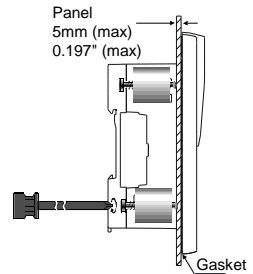

Wiring

Note: All diagrams are based on the rear view of the OPLC.



- Do not touch live wires.

Install an external circuit breaker. Guard against short-circuiting in external wiring.

Use appropriate circuit protection devices.



Unused pins should not be connected. Ignoring this directive may damage the device.

Double-check all wiring before turning on the power supply.

- To avoid damaging the wire, do not exceed a maximum torque of 0.5 N-m (5 kgf-cm).
- Do not use tin, solder, or any substance on stripped wire that might cause the wire strand to break.
- Install at maximum distance from high-voltage cables and power equipment.

Use crimp terminals for wiring; use 26-12 AWG wire (0.13 mm²-3.31 mm²).

- Strip the wire to a length of 7±0.5mm (0.250-0.300 inches).
- Unscrew the terminal to its widest position before inserting a wire.
- Insert the wire completely into the terminal to ensure a proper connection.
- Tighten enough to keep the wire from pulling free.

- Input or output cables should not be run through the same multi-core cable or share the same wire.
- Allow for voltage drop and noise interference with input lines used over an extended distance. Use wire that is properly sized for the load.

Inputs

- Both JZ10-11-R10 and JZ10-11-R16/V comprise I0-I5; these digital inputs are arranged in a single group. Via wiring, the entire group may be set to either pnp or npn.

The following information concerns JZ10-11-R16/V. In addition to I0-I5, these comprise the following:

- I6 and I7 may be wired as either digital or analog inputs. These may be wired as either:
 - npn digital inputs
 - pnp digital inputs
 - analog (voltage) inputs

In addition, 1 input may be wired as a pnp input, while the other is wired as an analog input. Note that if 1 input is wired as an npn input, the other may not be wired as an analog input.

- AN0 and AN1 are analog (voltage) inputs.

I/O Configuration

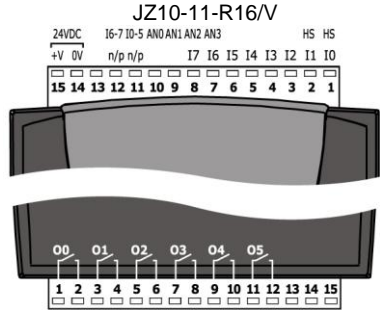
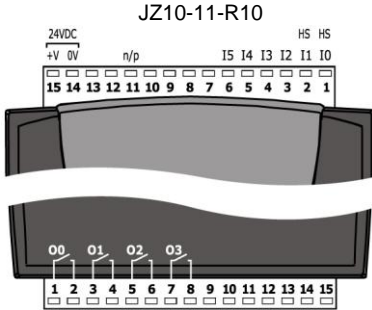

Digital Inputs, Controller's Power Supply

JZ10-11-R10

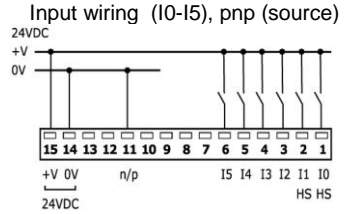
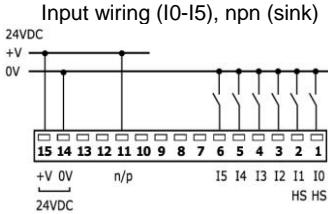

JZ10-11-R16/V

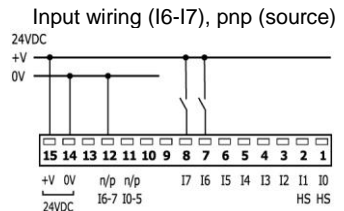
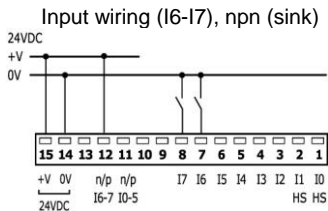
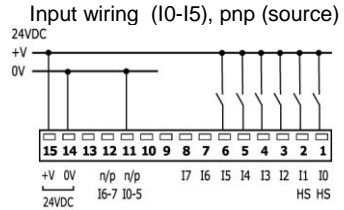
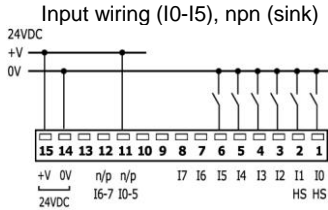

Digital Outputs

JZ10-11-R10

JZ10-11-R16/V

Output wiring

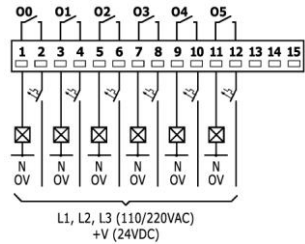
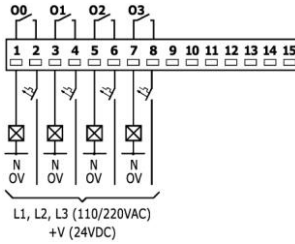

Increasing contact life span

To increase the life span of your contacts and protect the unit from potential damage by reverse-EMF, connect:

- A clamping diode in parallel with each inductive DC load
- An RC snubber circuit in parallel with each inductive AC load

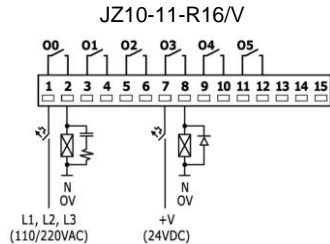
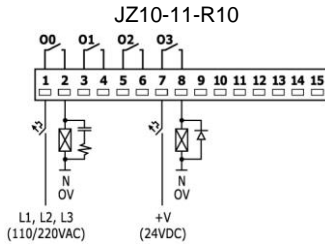

Analog inputs

Note: Shields should be connected at the signal source.

Analog Input wiring, current (JZ10-11-R16 only)

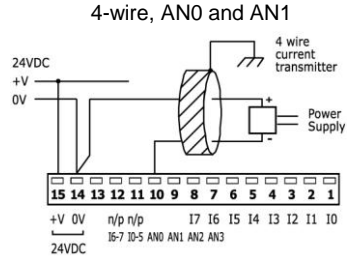
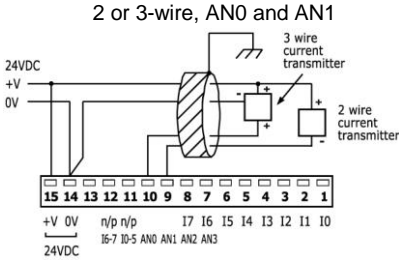

Analog Input wiring, voltage

Note: If either I6 or I7 is wired as an npn digital input, the remaining input may not be wired as an analog input.

JZ10-11-R16/V, AN2 and AN3

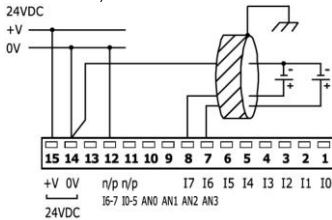

JZ10-11-R16V, AN0 and AN1

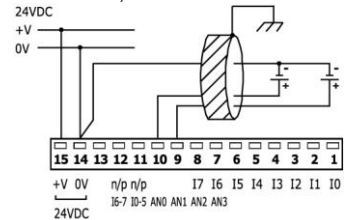

The information in this document reflects products at the date of printing. Unitronics reserves the right, subject to all applicable laws, at any time, at its sole discretion, and without notice, to discontinue or change the features, designs, materials and other specifications of its products, and to either permanently or temporarily withdraw any of the foregoing from the market.

All information in this document is provided "as is" without warranty of any kind, either expressed or implied, including but not limited to any implied warranties of merchantability, fitness for a particular purpose, or non-infringement. Unitronics assumes no responsibility for errors or omissions in the information presented in this document. In no event shall Unitronics be liable for any special, incidental, indirect or consequential damages of any kind, or any damages whatsoever arising out of or in connection with the use or performance of this information.

The trademarks, trademarks, logos and service marks presented in this document, including their design, are the property of Unitronics (1989) (R^G) Ltd. or other third parties and you are not permitted to use them without the prior written consent of Unitronics or such third party as may own them