

TECHNIACAL SPECIFICATIONS	
CONTANCT CARRIER MATERIAL	NYLON OR TPU/BLACK
MOLDED HEAD MATERRIAL/COLOUR	TPU/YELLOW
CONTACT MATERIAL/PLATING	BRASS/GOLD
COUPLING NUT MATERIAL/PLATING	ZINC DIE-CAST/NICKEL
OPERATING CURRENT	3A
OPERATING VOLTAGE	250V
OPERATING TEMPERATURE	-25°C~ +85°C
PROTECTION CLASS	IEC IP67,IN MATED CONDITION

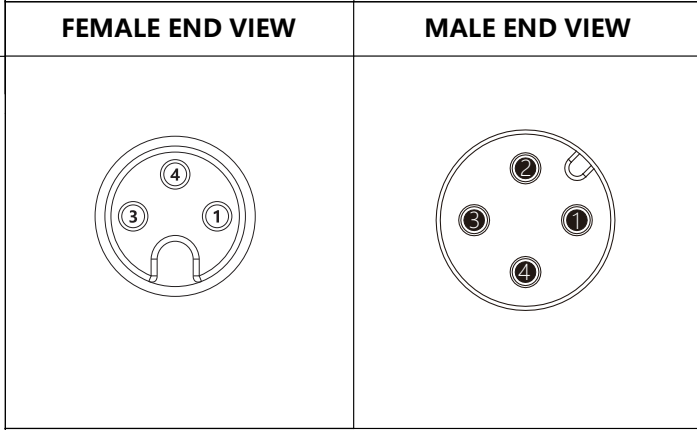

REV	CHG.	DATE	DESCRIPTION	REVISION

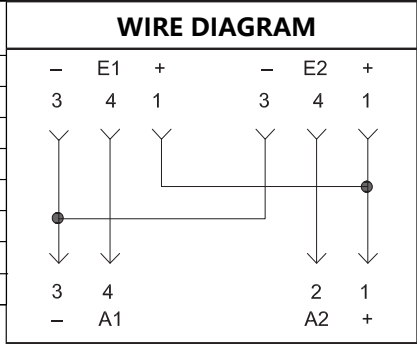
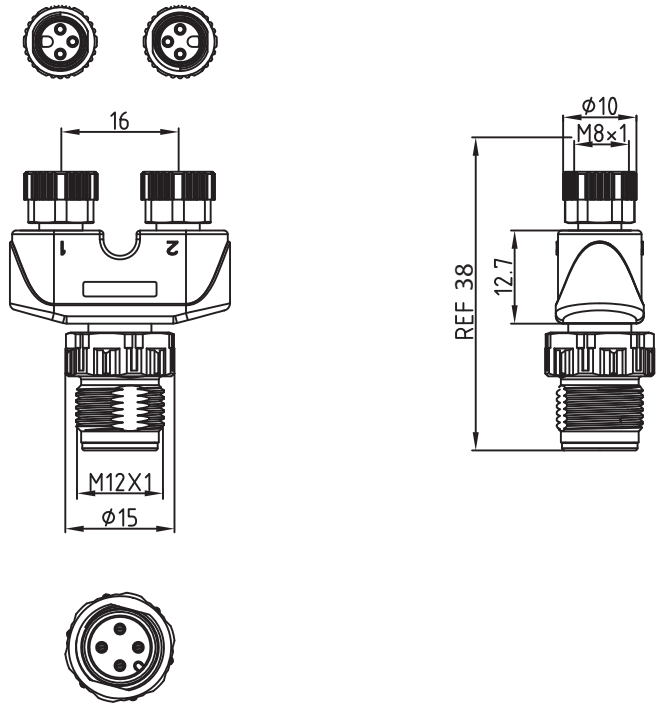

SOURCE DRAWING-FOR REFERENCE ONLY

APPROVED BY		DATE	
CHECKED BY		DATE	
DRAWING BY	SGY	DATE	2023.8.9
TOLERANCE UNLESS OTHERWISE SPECIFIED	CABLE LENGTH	TOLERANCE	
	ALL LENGTHS	+4%(OR 50mm) OF LENGTH -0%(OR 0mm) OF LENGTH WHICHEVER IS GREATER	
TOLERANCE UNLESS OTHERWISE SPECIFIED	STRIP LENGTH	TOLERANCE	
	0-7mm	±1.0mm	
	8-29mm	±1.5mm	
	30-49mm	±2.0mm	
	50-99mm	±3.0mm	
	70-100mm over 100mm	±4.0mm ±5.0mm	

UNITRONICS®

UNITS	mm	DESCRIPTION: ADP-M12AM4-2M8F3
1st Angle Projection		
		PART NO.
REV	A	SHEET
		1 OF 1